

Wallowa-Whitman National Forest



Radio and Frequency User Guide 2011

Revised 5/04/2011 (ww freq "final rev C")



Handheld

Mobile Radio

Guide may be reproduced via web at:

http://bmidc.org/radio_guides/wwf_radioguide.pdf

INDEX

1.Cover Page
2.Index
3.**Group Descriptions and How to Change Between Channel Groups**
4.**Repeater Location Map**
5.Group #1 Channel/Frequency List
6. Group #2 Channel/Frequency List
7. Group #3 Channel/Frequency List
8. Group #4 Channel/Frequency List
9. Group #5 Channel/Frequency List
10. Group #6 Channel/Frequency List
11.Group #7 Channel/Frequency List
12. Group #8 Channel/Frequency List
13. Group #9 Channel/Frequency List
14. Group #10 and #11 Channel/Frequency List
15. Group #12 and #13 Channel/Frequency List
16. Group #14 and #15 Channel/Frequency List
17. King Handheld Radio - Diagram with labels
18. **King Handheld Radio – Basic Operation**
19. King Handheld Radio – Manual Selection of a Tone
20. Vehicle Charge Guard Usage
21. **King Mobile (vehicle) Radio – Basic Operation**
22.
23. Programming – Advanced Users Only
24.
25. Cloning – Advanced Users Only

Group Descriptions (see pages 5-14 for channels in each group)

Group One* - Wallowa-Whitman and Oregon Dept of Forestry

Group Two*—Umatilla NF North Half

Group Three*—Umatilla NF South Half

Group Four*—Wallowa Fire Zone

Group Five*—Snake River Corridor

Group Six*—La Grande Unit - Rural

Group Seven—La Grande Unit

Group Eight*—Whitman Unit

Group Nine*—Whitman Unit - Rural

Group Ten—Malheur N.F. - Blue Mountain RD

Group Eleven—Malheur N.F. - Prairie City RD

Group Twelve—Wallowa-Whitman NF Repeaters (has all main repeaters on the WWF)

Group Thirteen— Snake River “Snake”

Group Fourteen—OCH/Dayville Central Oregon

Group Fifteen—W-W Type 3 IA Team

*** --- these groups require users to select tones manually.
See page 18 for instructions.**

To change between Channel Groups

Handheld and Mobile Radios (with keypad)

1. Press [#] on keypad.
2. Enter desired group number using keypad.
3. Press [ENT] or wait 5 seconds to go to selected group

Mobile Radios

1. Press [GRP] button on radio.
2. Rotate Channel Knob till desired group is displayed
3. Press [GRP] button or wait 5 seconds and new group will be selected.

Note: to just check what group is currently selected, just press [GRP] button. Radio will return to operating mode in 5 seconds.

Wallowa-Whitman National Forest Repeater Locations

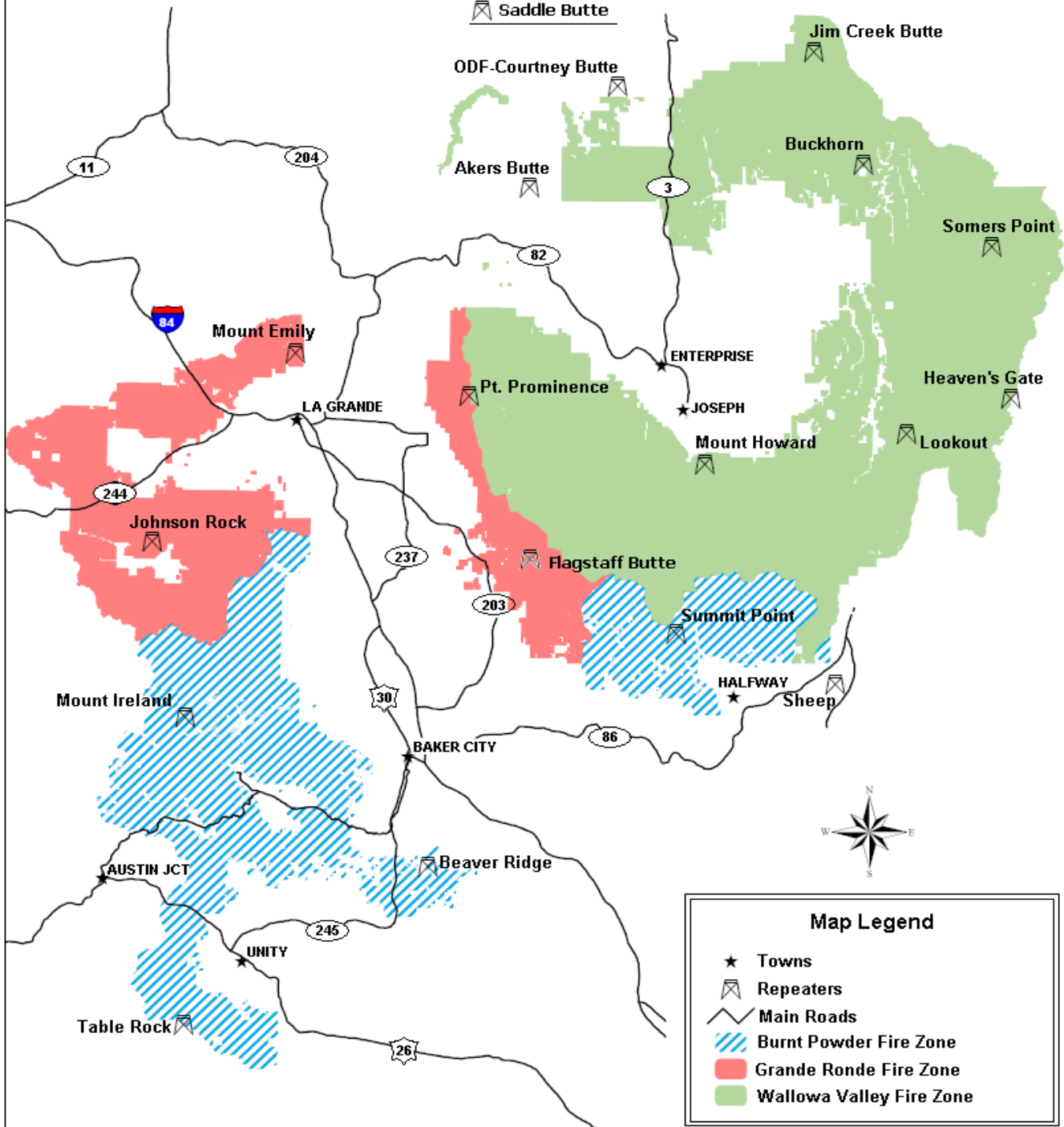

Group One - Wallowa-Whitman NF and Oregon Dept. of Forestry

Note: This group require user to manually select tones – see page 18 for instructions

Channel #	Name	RX Frequency	TX Frequency	Mode	FS Guard Tone	Tone Freq
1	W-W Wallowa	166.0000	164.0250	NB		
	Akers				1	110.9
	Buckhorn				2	123.0
	Mt Howard				3	131.8
	Lookout				6	156.7
	Somers				7	167.9
	Pt Prominence				8	103.5
	Saddle Butte				14	151.4
2	W-W Lagrande	170.5250	164.8000	NB		
	Mt. Emily				7	167.9
	Johnson Rock				8	103.5
	Flagstaff Butte				14	151.4
3	W-W Whitman	164.1500	168.1500	NB		
	Beaver				2	123.0
	Summit				3	131.8
	Mt Ireland				4	136.5
	Tablerock				5	146.2
	Sheep Mt.				6	156.7
4	N Direct	166.0000	166.0000	NB		
5	Lag Direct	170.5250	170.5250	NB		
6	S Direct	164.1500	164.1500	NB		
7	Project	164.9625	164.9625	NB		
8	AG CHARLIE	167.6250	167.6250	NB		
9	AG OSCAR	169.1500	169.1500	NB		
10	ODF South Rptr	151.2425	159.4050	NB		
	Beaver				15	162.2
	Mt Emily #2				3	131.8
11	ODF Lag Direct	151.2425	151.2425	NB		131.8
12	ODF North Rptr	151.1600	159.4425	NB		
	Mt Emily # 1				3	131.8
	Spout Springs				12	179.9*
13	ODF Courtney	151.4375	159.3975	NB	5	146.2
14	Red Net	151.3400	151.3400	NB	6	156.7
15	Whitenet	151.3100	151.3100	NB	6	156.7
16	Airguard	168.6250	168.6250	NB	1	110.9

Group Two—Umatilla NF North Half

Note: This group require user to manually select tones – see page 18 for instructions

Channel #	Name	RX Frequency	TX Frequency	Mode	FS Guard Tone	Tone Freq
1	UMF South Half Direct	164.1250	164.1250	NB		
2	A/G MIKE	170.0000	170.0000	NB		
3	UMF/WAF Project	164.9625	164.9625	NB		
4	A/G DELTA	167.3750	167.3750	NB		
5	Walla Walla	171.7875	163.3750	NB		
	Black Mtn Rptr				1	110.9
	Spout Springs				11	114.8
	Bone Springs				2	123.0
	Lookout Repeater				3	131.8
	Tablerock				8	103.5
6	ODF PDT	151.1600	159.4425	NB		
	Mt. Emily				3	131.8
	Black Mtn				13	141.3
	Spout				12	179.9*
7	Pomeroy	164.8250	169.0000	NB		
	Tallow Flat Rptr				6	156.7
	Cottonwood Rptr				3	131.8
	Robertson Field Rptr				2	123.0
	Saddle Butte Rptr				5	146.2
	Diamond Peak Rptr				14	151.4
	Oregon Butte Rptr				7	167.9
8	ODF Courtney	151.4375	159.3975	NB	5	146.2
9	Weather	162.4000		WB		
10	WA DNR	159.4200	151.2950	NB		
	Dayton Rptr				9	D223*
	Pasco Rptr				10	D271*
	Asotin				16	D365*
11	WA DNR Common TAC	151.4150	151.4150	NB	8	103.5
12	WA DNR AG	159.2700	159.2700	NB		
13	ODF White	151.3100	151.3100	NB	6	156.7
14	ODF Red	151.3400	151.3400	NB	6	156.7
15	OPEN	-	-	-	-	
16	AIR GUARD	168.6250	168.6250	NB	1	110.9

Group Three – Umatilla NF South Half

Note: This group require user to manually select tones – see page 18 for instructions

Channel #	Name	RX Frequency	TX Frequency	Mode	FS Guard Tone	Tone Freq
1	UMF North Half Direct	164.8250	164.8250	NB		
2	AG MIKE	170.0000	170.0000	NB		
3	UMF/WAF Project	164.9625	164.9625	NB		
4	AG DELTA	167.3750	167.3750	NB		
5	ODF PDT	151.1600	159.4425	NB		
	Mt. Emily Rptr				3	131.8
	Black Mtn Rptr				13	141.3
	Spout Springs Rptr				12	179.9*
6	Hepner	162.9625	166.6875	NB		
	Madison Butte Rptr				4	136.5
	Black Mtn South Rptr				13	141.3
	Tamarack Mtn Rptr				6	156.7
7	ODF John Day	151.2050	159.3750	NB		
	Dixie Butte Rptr				3	131.8
	Aldrich Mtn Rptr				15	162.2
8	North Fork	164.1250	170.3250	NB		
	Desolation Rptr				8	103.5
	Tower Mtn Rptr				13	141.3
	Bone Point Rptr				15	162.2
9	ODF WHITE NET	151.3100	151.3100	NB	6	156.7
10	ODF RED NET	151.3400	151.3400	NB	6	156.7
11	MAF PROJECT	170.5000	170.5000	NB		
12	MAF North , Blue Mtn. Ranger Dist	172.4000	169.5750	NB		
	Long Creek				1	110.9
	Dixie Butte Rptr				2	123.0
13	WWF LGRD RD	170.5250	164.8000	NB		
	Johnson Rock Rptr				8	103.5
	Mt Emily Rptr				7	167.9
14	NEW ODF	151.1450	159.2850	NB		
	Snowboard				12	179.9*
	Madison				14	151.4
15	OPEN	-	-	-	-	
16	AIR GUARD	168.6250	168.6250	NB	1	110.9

Group Four – Wallowa Fire Zone

Note: This group require user to manually select tones – see page 18 for instructions

Channel #	Name	RX Frequency	TX Frequency	Mode	FS Guard Tone	Tone Freq
1	WWF Wallowa Unit	166.0000	164.0250	NB		
	Akers Butte				1	110.9
	Buckhorn Springs				2	123.0
	Mt Howard				3	131.8
	Lookout Mtn				6	156.7
	Somers Pt				7	167.9
	Pt. Prominence				8	103.5
	Saddle Butte				14	151.4
2	NORTH End Direct	166.0000	166.0000	NB		
3	WWF ZAP Project	164.9625	164.9625	NB		
4	AG CHARLIE	167.6250	167.6250	NB		
5	AG OSCAR	169.1500	169.1500	NB		
6	ODF Courtney Rptr	151.4375	159.3975	NB	5	146.2
7	ODF White Net	151.3100	151.3100	NB	6	156.7
8	ODF Red Net	151.3400	151.3400	NB	6	156.7
9	Wallowa County	155.0250	155.7750	WB		
	Sheep Rptr				13	141.3
	Courtney Rptr				11	114.8
10	Enterprise FD TAC	153.7700	153.7700	WB		
11	Joseph FD TAC	153.8900	153.8900	WB		
12	Wallowa FD TAC	154.1600	154.1600	WB		
13	Wallowa County SAR	155.8050	155.8050	WB		
14	Weather	162.4000		WB		
15	OR State Fire Marshal	154.2800	154.2800	WB		
16	AIR GUARD	168.6250	168.6250	NB	1	110.9

Group Five – Snake River Corridor

Note: This group require user to manually select tones – see page 18 for instructions

Channel #	Name	RX Frequency	TX Frequency	Mode	FS Guard Tone	Tone Freq
1	W-W North End Repeat	166.0000	164.0250	NB		
	Somers				7	167.9
	Buckhorn				2	123.0
	Lookout				6	156.7
2	W-W ZAP Project	164.9625	164.9625	NB		
3	AG CHARLIE	167.6250	167.6250	NB		
4	AG OSCAR	169.1500	169.1500	NB		
5	Heaven's Gate/Jim Creek	164.0250	166.0000	NB		
6	NPF Heavens Gate Rptr	164.1375	169.1250	NB	4	136.5
7	NPF Com Use 1	163.7125	163.7125	NB		
8	NPF/IDL Air to Ground	151.1450	151.1450	NB	9	100.0
9	PAF Cold Springs Rptr	171.5500	172.3500	NB	5	146.2
10	PAF Tactical 1	166.9875	166.9875	NB		
11	PAF Air to Ground	167.4250	167.4250	NB		
12	IDL Jim Creek	159.2325	151.3325	NB	2	123.0
13	IDL/NPF Tactical 2	159.2850	159.2850	WB	11	77.0*
14	Idaho County	154.1150	156.0150	WB	12	127.3
15	Maritime Emergency	156.8000	156.8000	WB		
16	Air Guard	168.6250	168.6250	NB	1	110.9

Group Six – La Grande Unit – Rural

Note: This group require user to manually select tones – see page 18 for instructions

Channel #	Name	RX Frequency	TX Frequency	Mode	FS Guard Tone	Tone Freq
1	W-W Lagrande Repeaters	170.5250	164.8000	NB		
	Mt. Emily				7	167.9
	Johnson Rock				8	103.5
	Flagstaff Butte				14	151.4
2	ODF Mt Emily #2 Rptr	151.2425	159.4050	NB	3	131.8
3	Zap Project	164.9625	164.9625	NB		
4	Red Net	151.3400	151.3400	NB	6	156.7
5	White Net	151.3100	151.3100	NB	6	156.7
6	Union County Fire	154.4450	154.4450	WB	9	173.8*
7	Union County Tac 4	158.8200	158.8200	WB	9	173.8*
8	Union County OPS 5	155.1450	155.1450	WB	5	146.2
9	OR State Fire Marshal	154.2800	154.2800	WB		
10	AG CHARLIE	167.6250	167.6250	NB		
11	AG OSCAR	169.1500	169.1500	NB		
12	W-W Whitman Repeaters	164.1500	168.1500	NB		
	Beaver				2	123.0
	Summit				3	131.8
	Mt Ireland				4	136.5
	Tablerock				5	146.2
	Sheep Mt.				6	156.7
13	ODF Blue Net	159.2625	159.2625	NB	6	156.7
14	UMF North Fork Repeaters	164.1250	170.3250	NB		
	Desolation Rptr				8	103.5
	Tower Mtn Rptr				13	141.3
	Bone Point Rptr				15	162.2
15	OR State SAR	155.8050	155.8050	WB	6	156.7
16	Air Guard	168.6250	168.6250	NB	1	110.9

Group Seven – La Grande Unit

Channel #	Name	RX Frequency	TX Frequency	Mode	FS Guard Tone	Tone Freq
1	Zap Project	164.9625	164.9625	NB		
2	W-W Mt. Emily FS	170.5250	164.8000	NB		167.9
3	W-W Flagstaff Butte FS	170.5250	164.8000	NB		151.4
4	W-W Johnson Rock FS	170.5250	164.8000	NB		103.5
5	ODF Red Net	151.3400	151.3400	NB		156.7
6	ODF White Net	151.3100	151.3100	NB		156.7
7	Union County Fire	154.4450	154.4450	WB		173.8
8	ODF Mt Emily #2 Rptr	151.2425	159.4050	NB		131.8
9	W-W Summit FS	164.1500	168.1500	NB		131.8
10	W-W Beaver FS	164.1500	168.1500	NB		123.0
11	UMF North Fork Tower FS	164.1250	170.3250	NB		141.3
12	AG CHARLIE	167.6250	167.6250	NB		
13	AG OSCAR	169.1500	169.1500	NB		
14	OR State SAR	155.8050	155.8050	WB		156.7
15	OR State Fire Marshal	154.2800	154.2800	WB		
16	Air Guard	168.6250	168.6250	NB		110.9

Group Eight – Whitman Unit

Note: This group require user to manually select tones – see page 18 for instructions

Channel #	Name	RX Frequency	TX Frequency	Mode	FS Guard Tone	Tone Freq
1	Dixie North	172.4000	169.5750	NB	2	123.0
2	UMF-Desolation	164.1250	170.3250	NB	8	103.5
3	Wallowa-Whitman South	164.1500	168.1500	NB		
	Beaver				2	123.0
	Summit				3	131.8
	Mt Ireland				4	136.5
	Tablerock				5	146.2
	Sheep				6	156.7
4	South Direct	164.1500	164.1500	NB		
5	Zap Project	164.9625	164.9625	NB		
6	AG CHARLIE	167.6250	167.6250	NB		
7	AG OSCAR	169.1500	169.1500	NB		
8	ODF-South	151.2425	159.4050	NB		
	Beaver				15	162.2
	Mt Emily 2				3	131.8
9	ODF-LG Direct	151.2425	151.2425	NB	3	131.8
10	ODF-Red Net	151.3400	151.3400	NB	6	156.7
11	ODF-White Net	151.3100	151.3100	NB	6	156.7
12	OR State Fire Marshal	154.2800	154.2800	WB		
13	BLM-Lookout Mtn	172.6125	166.3750	NB	11	114.8
14	BLM-Beaver Rptr	166.3000	166.9000	NB	10	107.2
15	BLM-SOA Direct	173.6750	173.6750	NB	3	131.8
16	AIR GUARD	168.6250	168.6250	NB	1	110.9

Group Nine – Whitman Unit -Rural

Note: This group require user to manually select tones – see page 18 for instructions

Channel #	Name	RX Frequency	TX Frequency	Mode	FS Guard Tone	Tone Freq
1	ODF South	151.2425	159.4050	NB	15	162.2
2	ODF Red Net	151.3400	151.3400	NB	6	156.7
3	Whitman RD	164.1500	168.1500	NB		
	Beaver FS				2	123.0
	Summit				3	131.8
	Mt Ireland				4	136.5
4	AG OSCAR	169.1500	169.1500	NB		
5	ZAP Project	164.9625	164.9625	NB		
6	AG CHARLIE	167.6250	167.6250	NB		
7	ODF White Net	151.3100	151.3100	NB	6	156.7
8	State Fire Marshal	154.2800	154.2800	WB		
9	BLM Beaver Rptr.	166.3000	166.9000	NB	10	107.2
10	Baker County Interop	151.1375	151.1375	NB	6	156.7
11	Baker County Tac 1	158.7375	158.7375	NB	6	156.7
12	Baker County Tac 2	154.1000	154.1000	NB	6	156.7
13	Baker County Tac 5	154.1600	154.1600	NB	6	156.7
14	Baker County RED	153.9650	155.0550	NB		
	Baker City				11	77.0*
	Beaver Ridge				12	179.9*
	Lone Pine				14	186.2*
	Summit				10	107.2
	Sumpster				13	173.8*
	Lime				5	146.2
	Powder River Canyon				16	192.8
	Elkhorn Relay				1	110.9
15	OR State SAR	155.8050	155.8050	WB	6	156.7
16	Air Guard	168.6250	168.6250	NB	1	110.9

Group Ten – Malheur N.F. - Blue Mountain RD

Channel #	Name	RX Frequency	TX Frequency	Mode	FS Guard Tone	Tone Freq
1	North Long Creek	172.4000	169.5750	NB		110.9
2	North Dixie	172.4000	169.5750	NB		123.0
3	North Aldrich	172.4000	169.5750	NB		131.8
4	North Fall Mtn	172.4000	169.5750	NB		136.5
5	North Snow Mtn	172.4000	169.5750	NB		103.5
6	Project	170.5000	170.5000	NB		
7	North-PORTABLE	172.4000	169.5750	NB		100.0
8	AG DELTA	167.3750	167.3750	NB		
9	FireNet Fall Mtn	170.3500	170.3500	NB		136.5
10	FireNet Dixie	170.3500	170.3500	NB		123.0
11	ODF Direct	151.2050	151.2050	NB		162.2
12	ODF Red Net	151.3400	151.3400	NB		156.7
13	ODF White Net	151.3100	151.3100	NB		156.7
14	AG MIKE	170.0000	170.0000	NB		
15	BLM SOA Direct	173.6750	173.6750	NB		131.8
16	Air Guard	168.6250	168.6250	NB		110.9

Group Eleven – Malheur N.F. - Prairie City RD

Channel #	Name	RX Frequency	TX Frequency	Mode	FS Guard Tone	Tone Freq
1	East Dixie	173.0250	171.5750	NB		123.0
2	East Sheep	173.0250	171.5750	NB		146.2
3	East Antelope	173.0250	171.5750	NB		156.7
4	East King Mtn	173.0250	171.5750	NB		167.9
5	WW Tablerock	164.1500	168.1500	NB		146.2
6	Project	170.5000	170.5000	NB		
7	East - PORTABLE	173.0250	171.5750	NB		100.0
8	AG DELTA	167.3750	167.3750	NB		
9	North Dixie	172.4000	169.5750	NB		123.0
10	FireNet Dixie	170.3500	170.3500	NB		123.0
11	ODF Direct	151.2050	151.2050	NB		162.2
12	ODF Red Net	151.3400	151.3400	NB		156.7
13	ODF White Net	151.3100	151.3100	NB		156.7
14	AG MIKE	170.0000	170.0000	NB		
15	BLM SOA Direct	173.6750	173.6750	NB		131.8
16	Air Guard	168.6250	168.6250	NB		110.9

Group Twelve – Wallowa Whitman NF Repeaters

Note: this group is most useful for those employees needing access to main repeaters around the entire forest. Pool vehicles at S.O. should be kept in this group.

Channel #	Name	RX Frequency	TX Frequency	Mode	FS Guard Tone	Tone Freq
1	Akers Butte	166.0000	164.0250	NB		110.9
2	Buckhorn Springs	166.0000	164.0250	NB		123.0
3	Mt. Howard	166.0000	164.0250	NB		131.8
4	Lookout Mtn	166.0000	164.0250	NB		156.7
5	Somers Point	166.0000	164.0250	NB		167.9
6	Point Prominence	166.0000	164.0250	NB		103.5
7	Saddle Butte	166.0000	164.0250	NB		151.4
8	Mt. Emily	170.5250	164.8000	NB		167.9
9	Johnson Rock	170.5250	164.8000	NB		103.5
10	Flagstaff Butte	170.5250	164.8000	NB		151.4
11	Beaver Ridge	164.1500	168.1500	NB		123.0
12	Summit Point	164.1500	168.1500	NB		131.8
13	Mt. Ireland	164.1500	168.1500	NB		136.5
14	Table Rock	164.1500	168.1500	NB		146.2
15	Sheep Mtn.	164.1500	168.1500	NB		156.7
16	Zap Project	164.9625	164.9625	NB		

Group Thirteen– Snake River “Snake”

Channel #	Name	RX Frequency	TX Frequency	Mode	FS Guard Tone	Tone Freq
1	Cotton Wood (IDL)	159.4650	151.2650	NB		127.3
2	Jim Creek (IDL)	159.2325	151.3325	NB		123.0
3	NPF Cold Springs	164.1375	169.1250	NB		146.2
4	NPF Heavens Gate	164.1375	169.1250	NB		136.5
5	IDL TAC	159.2850	159.2850	WB		77.0
6	IDL Air to Ground	151.1450	151.1450	NB		
7	PAF Cold Springs	171.5500	172.3500	NB		146.2
8	PAF Sturgil	171.5500	172.3500	NB		123.0
9	PAF TAC	166.9875	166.9875	NB		
10	PAF Air to Ground	167.4250	167.4250	NB		100.0
11	WWF Somers Point	166.0000	164.0250	NB		167.9
12	WWF Lookout	166.0000	164.0250	NB		156.7
13	WWF ZAP Project	164.9625	164.9625	NB		
14	AG OSCAR	169.1500	169.1500	NB		
15	Idaho County	154.1150	156.0150	WB		127.3
16	Air Guard	168.6250	168.6250	NB		110.9

Group Fourteen– OCH/Dayville Central Oregon

Channel #	Name	RX Frequency	TX Frequency	Mode	FS Guard Tone	Tone Freq
1	BLM Aldrich Rptr	172.6500	163.1500	NB		123.0
2	ODF Aldrich Rptr	151.2050	159.3750	NB		162.2
3	OCH Aldrich Rptr	169.1250	168.1250	NB		151.4
4	OCH Wolf Rptr	169.1250	168.1250	NB		141.3
5	OCH Pisgah Rptr	169.1750	170.5500	NB		114.8
6	BLM Rancheria Rptr	172.6500	163.1500	NB		107.2
7	OCH NF Viewpoint Rptr	169.9750	168.7500	NB		114.8
8	OCH Stephenson Rptr	169.9750	168.7500	NB		151.4
9	OCH Round Mtn Rptr	169.1750	170.5500	NB		107.2
10	OCH Grizzly Rptr	169.9750	168.7500	NB		131.8
11	AG INDIA	166.6750	166.6750	NB		167.9
12	FS R6 Tactical 3	168.6000	168.6000	NB		
13	BLM TAC	173.6750	173.6750	NB		
14	ODF RED NET	151.3400	151.3400	NB		156.7
15	AG BRAVO	167.3000	167.3000	NB		
16	Air Guard	168.6250	168.6250	NB		110.9

Group Fifteen– W-W Type 3 IA Team

Channel #	Name	RX Frequency	TX Frequency	Mode	FS Guard Tone	Tone Freq
1	TAC 1	151.2350	151.2350	NB		156.7
2	TAC 2	151.2600	151.2600	NB		156.7
3	TAC 3	151.3550	151.3550	NB		156.7
4	TAC 4	151.3850	151.3850	NB		156.7
5	TAC 5	151.4150	151.4150	NB		156.7
6	TAC 6	151.4600	151.4600	NB		156.7
7	TAC 7	151.4750	151.4750	NB		156.7
8	CMD 1	170.5250	164.8000	NB		167.9
9	CMD 2	164.1500	168.1500	NB		123.0
10	PROJECT	164.9625	164.9625	NB		
11	RED	151.3400	151.3400	NB		156.7
12	WHITE	151.3100	151.3100	NB		156.7
13	AG OSCAR	169.1500	169.1500	NB		
14	AG CHARLIE	167.6250	167.6250	NB		156.7
15	OPEN					
16	AIR GUARD	168.6250	168.6250	NB		110.9

Operating King Handheld Radio

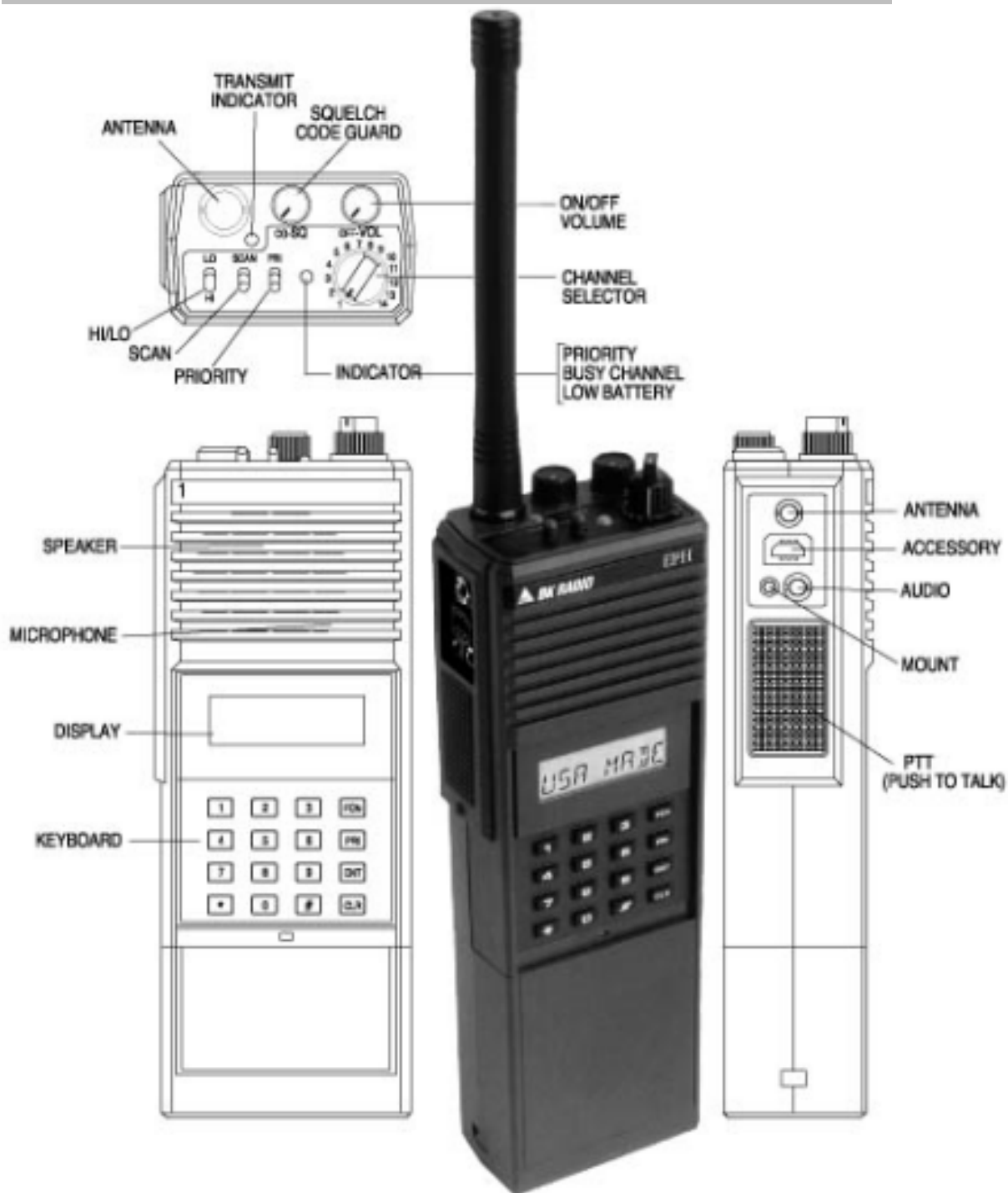

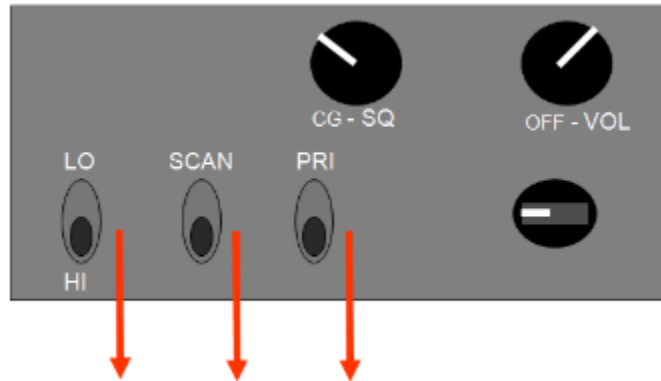

VOLUME AND SQUELCH KNOBS

To turn the radio on, rotate the volume knob to the right (clockwise). Additional rotation to the right increases the volume of reception. The squelch knob controls an electric circuit that cuts off the radio receiver when the signal is too weak for reception of anything but noise. Too low a squelch setting will cause continuous static. Too high a squelch setting will prevent lower-level signals from being received. The optimum setting may be achieved by turning the knob until continuous static is received, then backing off until the static just stops.

HI/LO SWITCH

The HI/LO switch selects the transmit power level. LO will minimize power draw, but will often be insufficient to contact your desired target, possibly even causing excessive transmit attempts and wasting even more power. It is therefore recommended to leave this switch set to HI, and to minimize your time transmitting by speaking succinctly. This switch has no effect on power draw when receiving.

PRIORITY AND SCAN SWITCHES

For basic operation the [SCAN] and [PRI] toggles should be flipped towards the front of the radio (keypad side).

BASIC OPERATION – King Handheld

RECEIVE

1. **TURN POWER ON** by turning the Volume knob clockwise. A beep sounds, indicating the radio is operational. The LCD display, if installed, shows the current channel.
2. **SELECT A CHANNEL** by turning the Channel Selector knob.
3. **ADJUST SQUELCH AND VOLUME** by turning the Squelch knob clockwise until you hear noise. Set the volume to a comfortable level. Then turn the Squelch knob counterclockwise until the noise stops. This is called the Threshold Squelch setting.

TRANSMIT

1. **PRESS THE PTT** (Push-To-Talk) switch. When the transmitter is on, the red Transmit Indicator glows and **TX** appears in the display.
2. **TALK IN A NORMAL VOICE** with the microphone 1–2 inches from your mouth.
3. **RELEASE THE PTT** switch to stop transmitting. If the Transmit Indicator does not glow when you press the PTT switch, the battery pack may need to be charged. If so, the display will indicate **LOBATT**, and the yellow Low-Battery Indicator will flash.

SELECTING A CHANNEL GROUP

1. **PRESS THE [#] KEY** on the keypad to display the current group number.
2. **PRESS A NUMBER KEY** for the new group number. Only valid group entries will be accepted. When changing groups, invalid entries will not be accepted, and the radio remains in the previously selected group.
3. **PRESS THE [ENT] KEY** or wait 5 seconds. The radio returns to normal operation for the new group, and the selected channel is displayed.

SELECTING A CHANNEL

Rotate the channel knob until the desired channel is selected and displayed on the screen.

* ---- SELECTING A TONE MANUALLY

(see page #3 for groups that require manual user selection)

1. Select the appropriate channel by rotating the channel selection knob.
2. Press the keypad # that corresponds to desired tone.
3. The channel # and tone # should now be displayed on the screen.

CH 2 ^{CG} 7

← This display shows “channel 2”, and “tone 7”

BATTERY INSTALLATION AND REMOVAL

INSTALLING THE BATTERY

1. **LOCATE THE CENTER HUB** on the radio base and place it in the recess of the battery pack.
2. **POSITION THE BATTERY PACK** at the 30° offset, seating the two metal studs in their recess.
3. **APPLY UPWARD PRESSURE** to the pack while twisting the pack to its original position. The metal tab will click, locking the pack in position.



REMOVING THE BATTERY

1. **TURN THE RADIO OFF.**
2. **PUSH UP THE METAL TAB** on the side of the case while twisting the battery pack approximately 30°.
3. **REMOVE BATTERY PACK** from the radio.

Charge Guard

Radios installed during or after field season of 2011, unless specified, will be equipped with a Charge Guard system mounted near the radio itself.

The Charge Guard will sense when your vehicle has been turned off. This will start a 30 Minute countdown and at the end of 30 minutes the radio will be shutoff preventing battery discharge.

The Charge Guard will also sense when engine has been started and within 10 seconds will provide power to the radio.

If for some reason the vehicles engine cannot be started and you need to use the radio there is an override built into the Charge Guard. Follow instructions below. This will power the radio for 30 Minutes.



Flip Open Rubber Cover

Push Button

LED Reference Guide

LED Off	= De-Energized (Off)
Solid Green	= Energized (Radio On)
Blinking Green	= Energized timer countdown
4 Blink Red	= High Voltage Condition
2 Blink Red	= Low Voltage Condition



Operating King Mobile

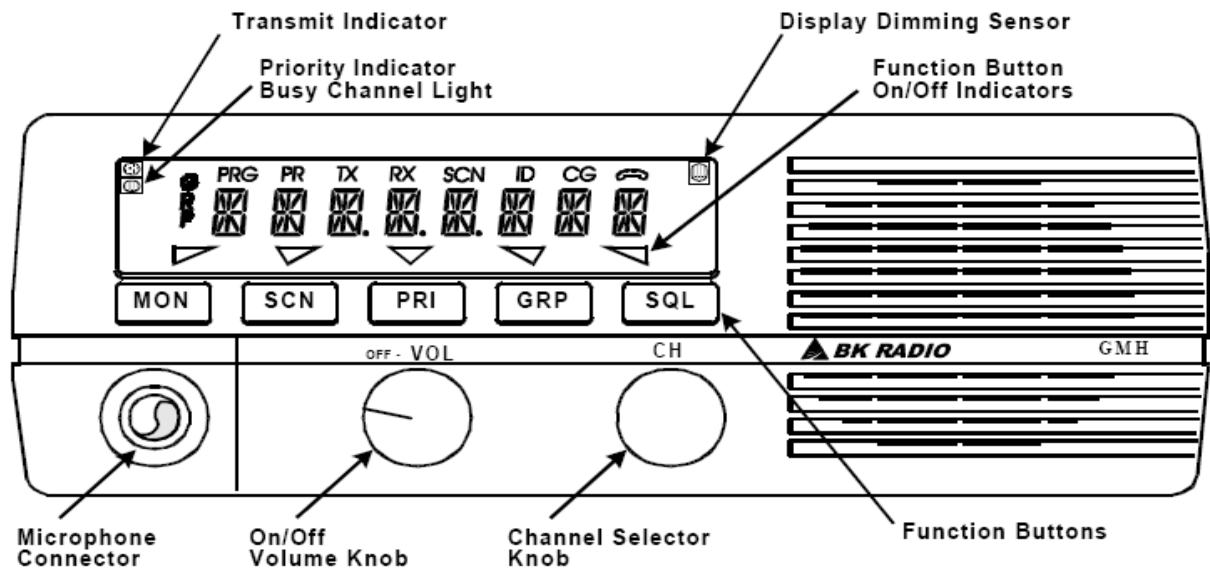

BASIC OPERATION

RECEIVE

1. Turn power on by rotating the Volume knob clockwise. The radio will beep, indicating that it has passed its self test and is operational.
2. Set volume by pressing the [MON] button to hear squelch noise. Turn the Volume knob to set a comfortable volume level. Press the [MON] button again to stop squelch noise.
3. Select a channel group (if applicable) by pressing the [GRP] button and turning the Channel Selector knob. Press the [GRP] button again to return to Channel Select mode.
4. Select a channel by turning the Channel Selector knob.

The display can show channel numbers (Numeric Mode), channel labels (Alphanumeric Mode). The Display Mode and Channel Labels are programmed by the technician.

TRANSMIT

1. Press the PTT (Push-To-Talk) switch on the microphone. The TX annunciator appears on the display and the red Transmit indicator illuminates while the PTT is pressed.
2. Talk in a normal voice with the microphone approximately one to two inches from your mouth.
3. Release the PTT switch to stop transmitting

* --- SELECTING A TONE MANUALLY

(see page #3 for groups that require manual user selection)

1. Select the appropriate channel by rotating the channel selection knob.
2. Press the keypad # that corresponds to desired tone.
3. The channel # and tone # should now be displayed on the screen.

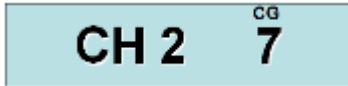

CH 2 ^{CG} 7

← This display shows “channel 2”, and “tone 7”

IMPORTANT!!

The following sections are for advanced users only!

Manual programming and cloning may cause your radio to not operate correctly. **Do not try this if you are not trained and authorized.**

When having your radio cloned, please change into one of the unused groups (group 15 and above) before cloning. This will insure your original programming located in the lower groups will not be affected and you radio will function when returning to home unit.

Warning!! Advanced/Authorized Users ONLY

Basic Programming



Handheld Radio

1. Insert program plug (sometimes called “bug”).
2. Turn Radio ON.
3. Press red button (on program plug) and [FCN] simultaneously; wait for beep. Display should read [-- -- -- ID].
4. Enter six 0's, and press [ENT]. Display should read [^{PRG} CH 00]
5. Enter the number of the channel to be programmed,
6. Press [FCN], display shows RX frequency
7. To Change, press [CLR]. Display shows [^{PRG} 0 . 0 ^{RX}]
8. Enter desired RX Frequency then press [ENT]
9. Display reads [^{PRG} 0 . 0 ^{RX} CG].
10. Press [ENT] again. Display shows [^{PRG} 0 . 0 ^{TX}]
11. Press [CLR] then enter desired TX Frequency then press [ENT].
12. If you mess up, just turn radio off and repeat steps 2-11 until it's good.
13. When complete turn off radio and then back on and conduct a radio check.

Warning!! Advanced/Authorized Users ONLY

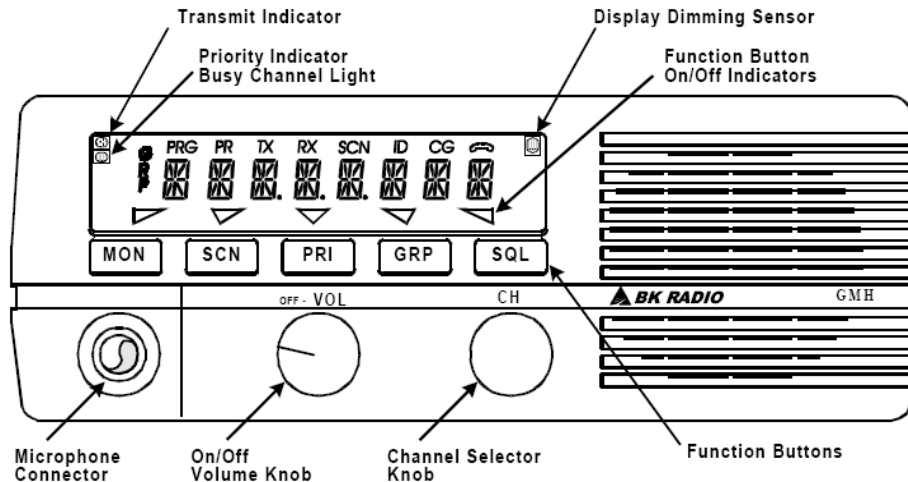

Basic Programming

Mobile Radio

1. Turn Radio ON.
2. Press [SQL] Function button on console and [FCN] on mic keypad simultaneously; wait for beep. Display should read [-- -- -- ID].
3. Enter six 0's, and press [ENT]. Display should read [^{PRG} CH 00].
4. Enter the number of the channel to be programmed.
5. Press [FCN], display shows RX frequency
6. To Change, press [CLR]. Display shows [^{PRG} 0.0 ^{RX}]
7. Enter desired RX Frequency then press [ENT]
8. Display reads [^{PRG} 0.0 ^{RX} ^{CG}].
9. Press [ENT] again. Display shows [^{PRG} 0.0 ^{TX}]
10. Press [CLR] then enter desired TX Frequency then press [ENT].
11. If you mess up just turn radio off and repeat steps 2-11 until it's good.



When complete turn off radio and then back on and conduct a radio check.

CLONING

IMPORTANT: When having your radio cloned, please change into one of the unused groups (**group 15 and above**) before cloning. This will insure your original programming located in the lower groups will not be affected and you radio will function when returning to home unit.

Warning!! Advanced/Authorized Users ONLY



Cloning a King handheld radio:

1. Select desired group on master and slave radios
 - a. Example: to get to group 7, press “#”, “7”, “ENT”
2. Connect cables to appropriate ends (see cheat sheet)
3. Turn on master radio, if not already on
4. Put master radio in program mode by holding down **Cable Button** and “FCN” button on radio
5. Enter password --- **000000** then press “ENT”
6. Turn on Slave radio
7. Press “* ” **key** on master radio (the display will read “PROG”)
8. Press “FCN” on the master radio – the slave will now be cloned
9. If cloning is successful, master radio will resume flashing “PROG”
10. If cloning fails, master will flash “FAIL”. To clear this message, press “CLR” key.

NOTE: To stop FAIL mode, press [CLR], turn radios off and repeat steps 1-8.

You can now connect another slave radio, and you'll only have to press “FCN” on the master to clone it.

Connecting Cloning Cables

